

# 400/658W PS/2 Dual AC Mini Redundant Power Supply

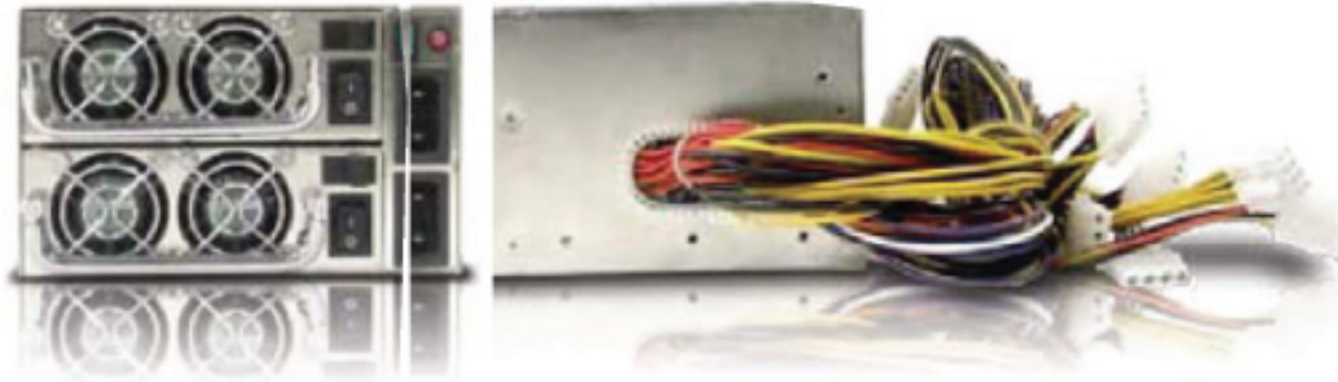

## INTRODUCTION

With its Hot-Swap & Power Sharing features, the RRA Series can significantly increase the reliability of a computer system and minimize the total down time. The RRA Series is the ideal power source for telecommunications systems and industrial systems, as well as for a variety of other mission critical applications.

## FEATURES

- PS/2 Size Design
- Over Power Protection
- Over Voltage Protection
- Short Circuits Protection
- Auto Select AC Input
- Hot-Swappable & Power Sharing Capability
- Real Dual AC Input Design: AC-1: Primary Source, AC-2: Secondary Source

- A Air Cell Vent
- B Signal Release Latch
- C Module Status LED
- D Industrial Grade Connector
- E Alarm reset Switch
- F Power Switch
- G AC Input Fuse

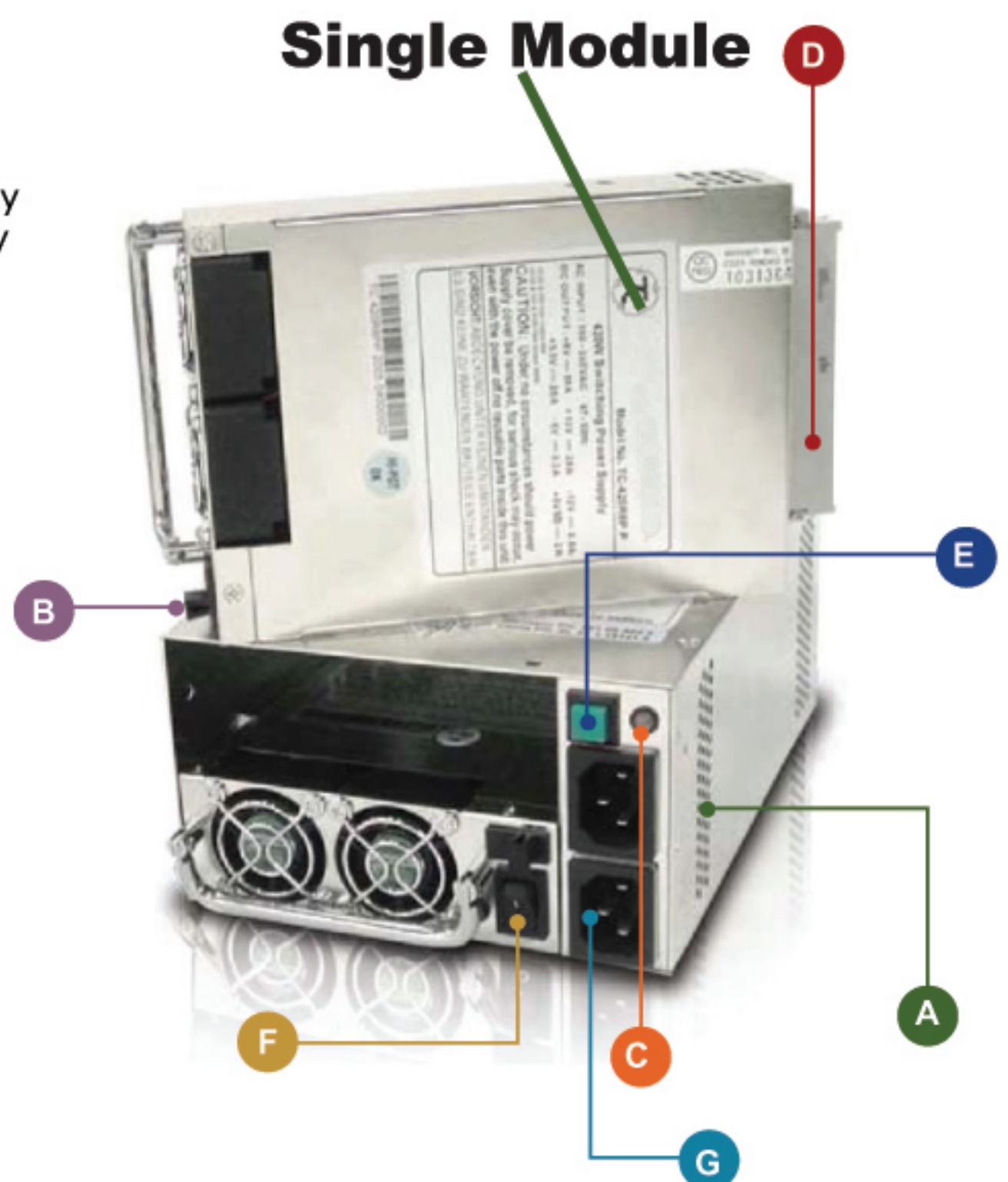

# Mini Redundant Manual

## DRAWING



20+4 Pin Connector



4 Pin Connector



3 External Status LED



8 Pin Connector



Peripheral Connector



Floppy Connector

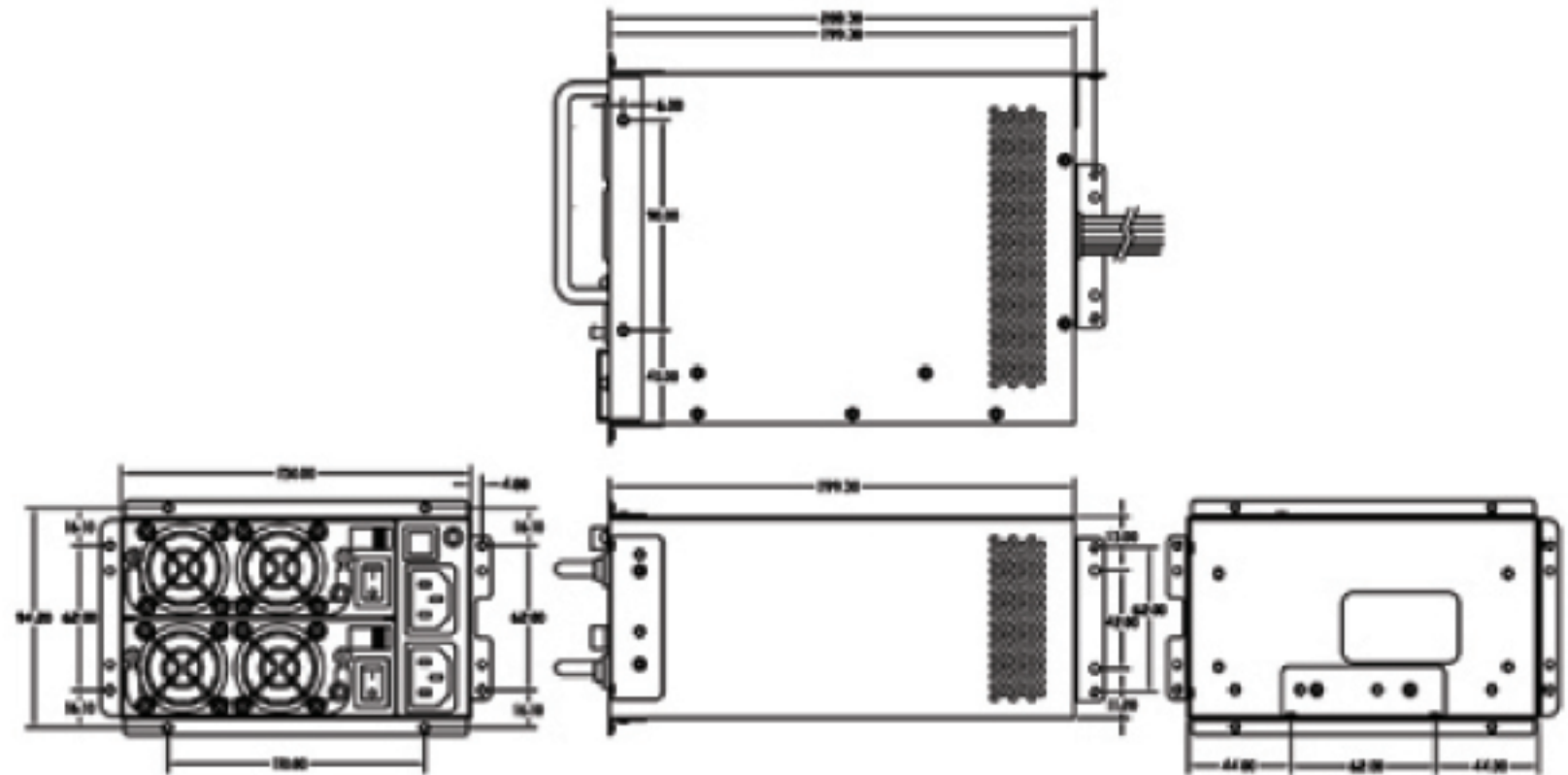

## SPECIFICATIONS

Model Number	RRP4ATX30	RRP4ATX40	RRP4ATX65
RoHS Compliance Version	Yes		
Output Power	300W	400W	658W
AC Input	90V to 132V or 180V to 264V auto selectable 47Hz ~ 63Hz		
Main Connector	20+4 Pin		
12V Connectors	8-Pin / 4-Pin		
Dimensions [WxHxD]	150 x 86 x 200 mm		

## OUTPUT TABLE

Voltage	+3.3V	+5V	+12V	-12V	-5V	+5Vsb
Max Load	RRP4ATX30	12A	18A	18A	0.8A	2A
	RRP4ATX40	18A	20A	28A	0.8A	2A
	RRP4ATX65	18A	28A	36A	0.8A	2A
Min Load	0.3A	3A	2A	0.1A	0.1A	0.1A
Regulation	±0%	±5%	±5%	±0%	±5%	±5%
Ripple (mV)	50	50	120	120	50	50

## COMPARTIBLE CHASSIS

**4U SERIES / 4045,4055,4064X,4038X,4830....**  
**TOWER SERIES / SWH01, SWH02..... 3U SERIES / 364AF.....**

- :: Operation Temperature: 0°C to 50°C
- :: Humidity: 5 to 90°C non-condensing
- :: Specification and wiring diagram subject to change without notice
- :: 3 year standard Warranty
- :: Last Update: Oct/2008



Athena Computer Power Corp.  
 Mini Redundant Power Supply  
 300W+300W  
 400W+400W  
 658W+658W

Sym.	Indication
A	Inlet AC Master Source (AC1)
B	Inlet AC Second Source (AC2)
C	Alarm Display
D	Alarm Reset
E	Fasten Latches
F	Cooling Fan
G	Handle
H	LED Status Display
I	Main Power Switch

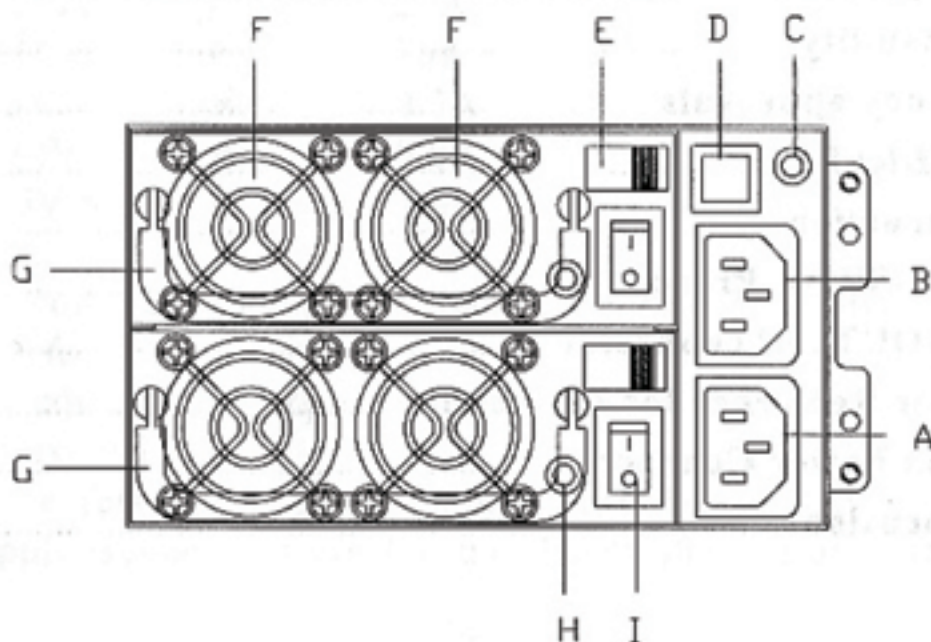

Athena Computer Power Corp.  
Mini Redundant Power Supply  
300W+300W  
400W+400W  
658W+658W

Table of content

<b>1. Introduction</b> .....	1
<b>2. Specification</b>	
2.1 Input Voltage .....	1
2.2 DC Output .....	1
2.3 PS-ON (Remote ON/OFF).....	2
2.4 PW-ON (power good signal) .....	2
2.5 Efficiency .....	3
2.6 Hold-Up Time.....	3
<b>3. PROTECTION</b>	
3.1 Over Voltage protection.....	3
3.2 Short Circuit Protection.....	3
3.3 Over Power Protection.....	3
3.4 No Load operation.....	3
<b>4. Environment Temperature</b> .....	3
<b>5. Reliability</b> .....	3
<b>6. Agency approvals</b> .....	3
<b>7. EMI/RFI</b> .....	4
<b>8. Instructions</b> .....	4
<b>9. HOT-SWAP Procedures</b> .....	4
<b>10. PINOUTS of connectors</b> .....	5
<b>Color Reference for LED cable</b> .....	5
<b>Main Power Connector</b> .....	5
<b>11. Dimension</b> .....	5

## **1. Introduction**

RRP4ATX Series products of **HOT-Swap & Power Sharing** redundant Power supply provides increased reliability when integrated a variety of Systems. RRP4ATX series is ideally suited to telecommunications and Industrial system, as well as a variety of other applications where system Never shut down i. E. Zero down time. AP-RRP4ATX series redundant power supply, it consists of

- \* One of passive Back plane.
- \* One of exothermal enclosure.
- \* Two of compact size power modules with Hot-Pluggable connector made by Germany.
- \* Screw package.
- \* Alarm reset bottom.

### **© Features**

- \* PS/2 Size design.
- \* Hot-Swappable & Power Sharing capability. (Patent no. 136053)
- \* Dual AC IN-Put design. AC-1 be Master source, AC-2 be Second source (Patent. Taiwan, Germany, USA, China)
- \* Auto Select AC input.

## **2. Specification**

2.1 AC Input Voltage: 90-132V or 180-264V auto select 50 to 60 Hz.

2.2 DC Output:

See above

### 2.3 PS-ON

#### Remote On/Off Control:

When PS-ON is pulled to TTL Low, the DC output is to be enabled.  
When PS-OFF is pulled to TTL high, the DC output is to be disabled.

### 2.4 PW-OK

PW-OK is power good signal and should be asserted high by the power supply to indicate that +5VDC and +3.3VDC output are above the under voltage thresholds of the power supply TTL compatible signal out with 100ms to 500ms.

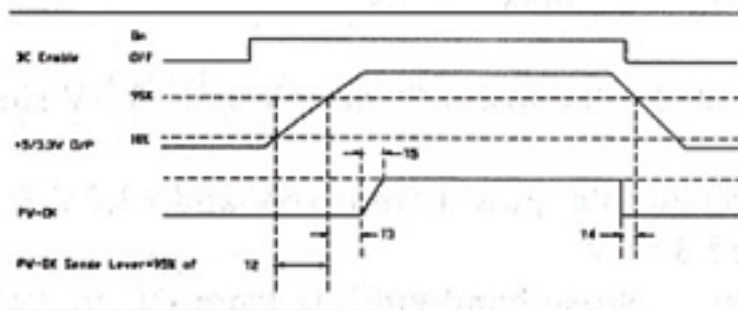

Timing of PS-ON, PW-OK, and Germane Voltage Rails

Although there is no requirement to meet specific timing parameters,

The following signal timings are recommended:

$2\text{ms} \leq T2 \leq 200\text{ms}$

$100\text{ms} \leq T3 \leq 500\text{ms}$

$T4 > 1\text{ms}$

$T5 \leq 10\text{ms}$

2.5 Efficiency: minimum 65% at full load. (Normal Line)

2.6 Hold-Up Time: 16ms at maximum load & normal input voltage.

### **3. PROTECTIONS**

#### **3.1 OVER-VOLTAGE PROTECTION**

Standard on +5.0V output, set at  $6.25\text{VDC} \pm 0.75\text{VDC}$ .

#### **3.2 SHORT CIRCUIT PROTECTION**

A Short circuit placed between the DC Return and the output shall cause

No damage and the power supply shall shutdown.

#### **3.3 OVER POWER PROTECTION**

The power supply shall shut down when output power exceeds 130% to 160% of full load and require a power on cycle be performed by the operate

#### **3.4 NO LOAD OPERATION**

No parts shall be damaged on the power supply.

### **4. ENVIRONMENT TEMPERATURE**

4.1 Operation Temperature:  $0^{\circ}\text{C}$  to  $50^{\circ}\text{C}$

4.2 Cooling: By forced air

4.3 Storage Temperature:  $-20^{\circ}\text{C}$  to  $70^{\circ}\text{C}$

4.4 Humidity: 5 to 90% non-condensing.

### **5. RELIABILITY**

#### **5.1 MTBF OF POWER SUPPLY ELECTRONIS**

100,000 hours at full load and  $25^{\circ}\text{C}$  ambient temperature

#### **5.2 LIFE EXPECTANCY OF FAN**

40,000 HOURS AT  $40^{\circ}\text{C}$

### **6. AGENCY APPROVALS**

UL 1950 QQGQ2

UL 1950 QQGQ8

TUV Rheinland (EN60950, IEC950mod)

CB Certification

## **7.EMI/RFI**

FCC part 15, Subpart B, Class B  
EN55022 CISPR22 Class B, CE Make  
EN61000-3-3; 1995  
EN61000-4-2, -3, -4, -5, -6, -8, -11

## **8.INSTRUCTIONS**

The set still works properly even if either unit is removed. The removed unit can't be used in other machinery nor for other purpose. When one unit breaks down, it's LED will blink, buzzer will sound. Push the Reset button and buzzer will stop.

**REDUNDANCY** Offer redundant function for power system and mutually backs up the outputs. A zero transfer time when backup takes place.

**HOT-SWAP** The power system provides a Hot-Swap function. This means when either one of the redundant power supplies fails or breaks down, you can easily replace failed unit without any interference to the system.

**BUZZER** A warning buzzer sounds when any one of the power supplies fails. The warning buzzer is re settable from reset switch either the one in front control panel or the one on the rear side.

**LED'S** The warning LED'S can be found either on the rear side or the control panel of the power system. Tells if one of the two power supplies has failed, by LED blinking.

**HOT-PLUGGABLE** The power system provides a Hot-Pluggable function This method allows the power units in the Disk Array/File Server to be removed or inserted very easily without

## **9.HOT-SWAP PROCEDURES**

Please refer to the followings when either one power supply unit is found defective.

**A) Locate** the defective power supply by examining the individual LED on the power unit or the LED on the front control panel if LED is Blinking.

**B) Unlock & Remove** the defective power supply unit.

- C) Replace a new GOOD power supply unit, Insert the power supply into the power system chassis in position & it will auto Lock-up.
- D) Turn on the new power supply unit.
- E) Check the module LED which indicate the power and LED of total power system status, Both LED shall Have steady life.

## 10. LED cable

### \* Color Reference for LED cable

POWER#1 LED Cable	Brown / with
POWER#2 LED Cable	Red / with
MAIN POWER LED Cable	Green / with

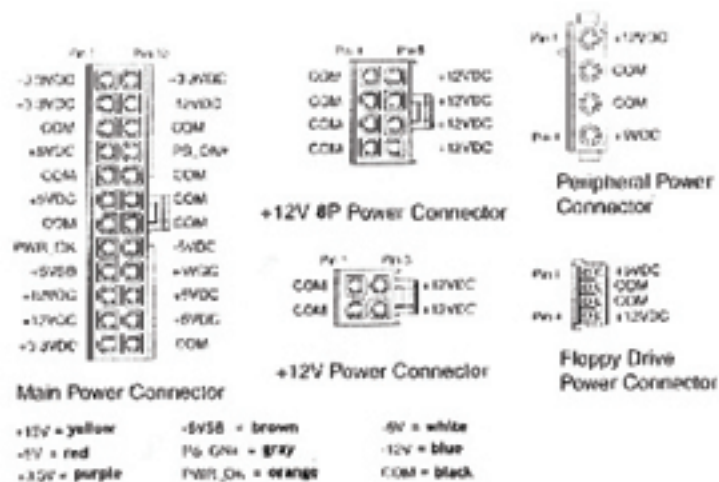

## 11.DIMENSION

L 200 x W150 x H 86 mm

